



## **2012 GINETTA JUNIOR IRELAND TECHNICAL REGULATIONS**

### **10. INTRODUCTION**

**10.1** Each Ginetta race car is manufactured to an identical class specification. In the interests of fairness and safety, competitors may not depart from this specification under any circumstances, other than as specified below.

**10.1.1** All Ginetta manufactured parts and in particular body panels must be supplied by Ginetta Cars Ltd (or in the case of force majeure a supplier nominated by the organisers) and fitted in their original position.

**10.1.2** Whilst the Eligibility Scrutineer is empowered to check all competing vehicles for compliance and has been provided with the data to determine the continuing eligibility of each car, the onus of responsibility for the eligibility of vehicles competing in this Championship, rests with the Entrant / Competitor. In the event of a dispute concerning the compliance of a vehicle with these Regulations, the onus will be on the Entrant / Competitor to satisfy the Organisers with regard to such compliance, and NOT the Organisers to prove non-compliance.

**10.1.3** Where it is suspected that a component or structure fitted to the competing vehicle may render the vehicle ineligible under these regulations, the component or access to the component will be sealed by the Eligibility Scrutineer, or a Scrutineer delegated by the Eligibility Scrutineer or MI Technical Advisory Group, for subsequent examination. Where ineligibility is subsequently proven, all points accrued by the competitor from and including the date of sealing the said component, to the date of examination, shall be forfeit.

**10.1.4** Where costs are incurred as a result of any eligibility check, as may be reasonably requested either by the Eligibility Scrutineer of the Championship Organisers, these will be borne by the competitor / entrant. Refer Appendix 2, Article 28.5.

**10.1.5** As a method of control, any component on a competitor's car may be removed by the Eligibility Scrutineer or a Scrutineer delegated by the Eligibility Scrutineer or MI Technical Advisory Group and exchanged for a similar component from the car of

another competitor, or provided by the Championship Organisers. This includes the ECU. Whilst efforts will be made to ensure that the condition of the exchanged parts is similar, responsibility for the care of exchanged components lies with the recipient. Exchanged components may be returned to their original owners on completion of the race.

**10.1.6** Any infringement of the Technical Regulations will render the competitor liable to penalties as defined in Article 4.1.3 of the Ginetta Junior Ireland Sporting Regulations.

**10.1.7** Cars will be issued at the start of each season with log books. These will be used to record information relating to that car during the season. The Entrant/Driver of each car will be responsible for the safe keeping of the log book which shall be presented with the car at pre-event scrutineering and when requested by the scrutineer.

**10.1.8 IT MUST BE CLEARLY UNDERSTOOD THAT THE OVERRIDING PRINCIPLE OF THESE REGULATIONS IS THAT UNLESS IT IS STATED THAT YOU CAN DO IT, YOU SHOULD WORK ON THE PRINCIPLE THAT YOU CANNOT.**

### **10.2 GENERAL DESCRIPTION**

**10.2.1** The **2012 GINETTA JUNIOR IRELAND CHAMPIONSHIP** is a 'one make' race series, for competitors participating in the Ginetta G20 GT4 Coupe cars as specified herein.

### **10.3 SAFETY REQUIREMENTS**

**10.3.1** The Ginetta G20 GT4 race car is manufactured to comply with the safety requirements of Appendix J of the FIA Technical Regulations for Production Sports Cars (MI Appendix 2) and must be retained.

Roll Cage with side and rear safety protection bars in compliance with MI Appendix 2, Article 16 of the **2012** Yearbook compliant with FIA Appendix J 159.15.1. Homologated 6 point safety harness compliant with FIA Appendix J Article 259.14.2.1 (FIA Standard 8853/98), MI Appendix 2, Article 7 of the **2012** Yearbook.

Fire system plumbed in compliant with FIA Appendix J Article 259.14.1. This system must be in the 'armed' condition (i.e. capable of being operated without the removal of any safety device) at all times whilst competing or practicing. The fire extinguisher cannot be disarmed in any Parc Ferme area without the specific permission of the Eligibility Scrutineer. Any system found to be incapable of being operated by virtue of the imposition of a safety device (e.g. pin) having been made whilst the vehicle is either competing or in Part Ferme, will be subject to report

to the Clerk of the Course for possible penalisation as an offence against Safety Regulations.

Single fog lamp, which in the Ginetta is integral with the rear light cluster, is used as a rain light.

Internal Fuel filler that can be positively closed

External Circuit Breaker

Built in head restraint with FIA homologated safety seat, compliant with FIA Appendix J Article 253.16.

**10.3.2** Cars will be fitted with an FIA homologated safety fuel cell that is compliant with FIA Appendix J Article 253.14.

**10.3.3** Drivers will wear FIA homologated race overalls to standard FIA 8856-2000 [2012 MI Yearbook Appendix 2, Article 23] and Helmets in accordance with [2012 MI Yearbook Appendix 2, Article 17].

**10.3.4** The use of a head and neck support system (HANS) according to the FIA Code, standard 8858-2002, is compulsory. The helmet manufacturer must certify the tether anchorages and their mounting.

## 10.4 GENERAL TECHNICAL REQUIREMENTS

**10.4.1** Competitors are reminded that a catch tank must be fitted and that the location of the vehicle towing eyes should be suitably marked.

**10.4.2** Towing eyes must be fitted in easily accessible locations at the front and rear of the car.

**10.4.3** From time to time it will be necessary to approve alternative equivalent components. Only components approved as alternatives and published as such by the Organisers and/or their appointed representatives in official amendments to these regulations are eligible to compete in the 2012 Ginetta Junior Ireland Series.

**10.4.4** In case of force majeure, Ginetta Cars may at any time approve alternative components. Competitors will be notified of any changes to the regulations via a published bulletin.

## 10.5 CHASSIS

**10.5.1** The Ginetta G20 is manufactured to a standard specification. Only original Ginetta G20 chassis will be eligible for Ginetta Junior Ireland.

## 10.6 BODYWORK

**10.6.1** The Ginetta G20 GT4 race car body is manufactured to a standard specification. Where necessary, it is permitted to weld an extended hoop

to the roll cage, to ensure that taller drivers are able to comply with MI Yearbook Appendix 2 Article 16.3. A template, verified via Ginetta Cars, may be used at scrutineering to ensure that the original bodywork shape and profile has not been altered in any such way that it deviates from its original shape and specification.

**10.6.2** All body parts, including panelling must be supplied through Ginetta Cars Ltd. Minor fibreglass repairs may be undertaken by the competitor, provided that the body profile is not altered in any way and the repair work is acceptable to the Eligibility Scrutineer/Ginetta Junior Ireland Organisers. Additional ventilation holes may be cut into the front panel and sides of the bonnet to the official Ginetta template (as per Appendix C of these Regulations).

**10.6.3** Additional ventilation holes may not be cut into the front panel unless written consent has been given by Ginetta Cars Ltd.

**10.6.4** Additional ventilation holes may be cut into the sides of the bonnet to the official Ginetta template (as per Appendix C). Metal mesh grills must be fitted to the ventilation apertures on the upper face of the bonnet. No extra panelling, either under floor or around the wheel arch area, is permitted.

**10.6.5** A template, verified via Ginetta Cars Ltd, may be used at scrutineering to ensure that the original bodywork shape and profile has not been altered in any such way that it deviates from its original shape and specification.

**10.6.6** Metal mesh grills must be fitted to the ventilation apertures on the upper face of the bonnet. The metal mesh grills must not protrude above the upper-most face of the bonnet. No extra panelling, either under floor or around the wheel arch area, is permitted.

**10.6.7** The standard rear-view mirrors may be replaced. Two rear-view mirrors must be fitted.

**10.6.8** The driver's seat may be changed with the approval of the Eligibility Scrutineer, but must be FIA homologated

**10.6.9** It is permissible to add hinges to the bonnet, to allow ease of access to the engine bay.

**10.6.10** The Ginetta Junior race bonnet should retain the original body profile as supplied by Ginetta Cars Ltd. and must be mounted above the front chassis mounting plates. In order to retain the original profile, the trailing edge of the bonnet base must be mounted no lower than the front chassis cross member. (see diagram below).

Diagram showing the side view of the minimum bonnet height

### Trailing edge of Bonnet Base bonnet

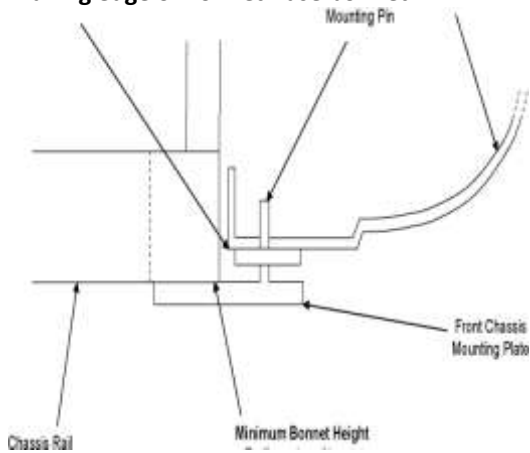

– Trailing edge of bonnet can be mounted no lower than the front chassis cross member.

**10.6.11** Standard front and rear windscreens, as supplied by Ginetta Cars Ltd. must be fitted.

**10.6.11.1** Additional ventilation into the driver cockpit to aid the cooling of the driver may only be authorised by the Eligibility Scrutineer. The structure of the ventilation must not contravene safety regulations or any of the technical regulations laid out within this document. The Eligibility Scrutineer will authorise the additional ventilation via a signature in the logbook.

## 10.7 PERMITTED ENGINE

The following specifications are for information only and are not intended to infer modification is in anyway allowed.

**10.7.1** The Ginetta G20 GT4 race car is supplied with a Ford Zetec SE 1400cc.16 valve engine, in its 89.2PS (88.0 Bhp) @ 5500rpm form. Production tolerances within the engine are permitted as long as these are in compliance with the original engine design. No alterations to this standard specification are permitted. Ballancing not allowed.

**10.7.2** Competitors must ensure that the engine bears at least three seals that have been applied by either the Organisers or the Eligibility Scrutineer and recorded by the Eligibility Scrutineer. These will be positioned in such a way as to prevent subsequent removal of the cam cover and oil pump, and thereby preventing access to the internal components of the engine.

**10.7.3** Removal of these seals by competitors is not permitted. Seals may only be removed or replaced by the Eligibility Scrutineer or a Scrutineer delegated by the Eligibility Scrutineer or MI Technical Advisory Group. Should any competitor suffer engine failure then the engine may be sent to the Ginetta approved and nominated repairer or a replacement engine may

be obtained from Ginetta Cars Ltd. Only an engine supplied by Ginetta Cars Ltd. will be eligible for the championship. Engines must be sealed.

**10.7.4** Cylinder Block. The centre line of the cylinder bores must remain within Ford production tolerances. No offsetting of the cylinder bores is allowed.

**10.7.5** Cylinder Head. No work that removes, adds, replaces or transfers material is allowed on the cylinder head, or which may in any way alter the shape of a component or port, is permissible. Polishing or abrasive cleaning of either inlet or exhaust ports, and which may result in the removal of the original manufacturer's cast finish, is strictly prohibited. Plaining of gasket face not allowed.

**10.7.6** Manifolds. It is permissible to use only inlet and exhaust manifolds as supplied by Ginetta Cars Ltd. Polishing, abrasive cleaning, or otherwise altering the manifolds internally, is prohibited.

**10.7.7** Compression Ratio. The maximum compression ratio of will be controlled as follows: Minimum combustion volume in the cylinder head with spark plug fitted must be 42.4cc. Standard Ford cylinder head gasket with a minimum compressed thickness of 1.54mm. Minimum diameter of cylinder aperture is 82mm. The piston will protrude a maximum of 0.65mm out of the cylinder block with the piston at TDC.

**10.7.8** Camshafts. The only permitted camshafts are the standard Ford Zetec SE 1400cc production inlet and exhaust camshafts, as supplied by Ginetta Cars Ltd. Exhaust and inlet camshafts must not be interchanged. The authenticity and lift characteristics of camshafts will be subject to eligibility checks. Camshaft timing must remain unaltered as standard production specification, and may be subject to periodic checking.

**10.7.9** Pistons. Pistons must be standard production Ford Zetec SE 1400cc pistons unmodified in any way. All three piston rings must be fitted and must be standard Ford production components. The combustion chamber face of the piston cannot be modified.

**10.7.10** Connecting Rods. Ford Zetec SE 1400cc connecting rods must be as standard and within production tolerances. Polishing is prohibited.

**10.7.11** Crankshafts. A standard Ford Zetec SE 1400cc crankshaft must be used. Polishing is prohibited. Crankshaft journals must remain within Ford positional tolerances if a repair regrind is carried out. The crank journals may be reground for reclaim as long as the minimum crank weight is respected.

**10.7.12** Inlet and exhaust valves. These are to be of steel construction and to original Ford Specification

for this engine. Solid lifters are not permitted, nor alterations to the original hydraulic lifters supplied as standard. It is not permitted to "lock up" the hydraulics within the tappets.

**10.7.13** Valves must remain standard, no re-profiling or polishing is permitted. The seat angle must be maintained.

**10.7.14** Flywheel. The cast iron flywheel must remain as standard and as supplied by Ginetta Cars Ltd. No material may be removed or added to the flywheel. During scrutineering a standard flywheel supplied by Ginetta Cars Ltd. may be used for comparison

**10.7.15** Engine Mounts. The standard 2009 specification engine mounts, of part number GCE 0026, as supplied by Ginetta Cars Ltd. must be used.

## 10.8 TRANSMISSION / FINAL DRIVE

**10.8.1** The Ginetta G20 GT4 race car must retain the Ford 'Type 9' derived gearbox as supplied through Ginetta Cars Ltd. It is the competitor's responsibility to ensure that the following prescribed gear ratios are retained at all times during competition:

1st 2.20:1,  
2nd 1.54:1,  
3rd 1.21:1,  
4th 1.1:1,  
5th 0.87:1,  
Reverse 3.66:1.

The clutch as supplied by Ginetta Cars Ltd. with the 2009 specification engine must be retained in its original form, as must the standard unmodified flywheel. An ATB viscous limited slip differential as supplied by Ginetta Cars Ltd., with a final drive ratio of 3.92:1 must be used. The sealed 'Type 9' derived Gearbox and ATB limited slip diff may only be rebuilt by Ginetta Cars Ltd.

**10.8.2** The standard sump, as supplied by Ginetta Cars Ltd. with the 2009 specification engine must be retained in its original form.

## 10.9 INDUCTION SYSTEM

The standard induction system as supplied by Ginetta Cars Ltd., and consisting of a single throttle body of bore size 48mm, fitted with a Pipercross filter, and mounted on a plenum chamber conforming to 2009 spec. must be retained. No modification to this system, or inclusion of additional structures between the plenum chamber and throttle body assembly is permissible. The throttle body housing shall not be modified internally in any way. No polishing or re-profiling is permitted. The external throttle linkage, including the throttle return spring, may not be reworked.

## 10.10 ELECTRICS

**10.10.1** Battery. The front location of the battery must be retained. Its type may be altered.

**10.10.2** Sparking plugs are free, provided they fit the engine without any modification to the cylinder head or the sparking plug and that the sparking plugs place the spark gap in the same position as the production sparking plug within the combustion chamber.

**10.10.3** The coil unit may be repositioned.

**10.10.4** It is prohibited to use any other method or component to trigger, distribute or time the ignition or injection.

**10.10.5** The fitting of additional instrumentation is permitted provided that such equipment does not affect the vehicle's performance.

**10.10.6** On board data acquisition systems are permitted but these may receive input from a speed sensor on one non-driven wheel only at any one time. All other sensors are free but must not affect the performance of the car and remain independent of the ignition management of the engine. All data from acquisition systems must be made available to Ginetta Cars Ltd. or the Eligibility Scrutineer at any time. No additional connections may be made to the ECU whatsoever. However, as a routine part of eligibility control procedures, portable data logging equipment may be fitted to any competing vehicle at the request of either the Organisers or Eligibility Scrutineer, for the purpose of collecting engine performance data during either race or qualifying sessions.

**10.10.7** Electronic Control Unit (ECU). The standard DTA Motorsports DTA-Fast S40PRO ECU as supplied by Ginetta Cars Ltd. must not be modified in any way, and must be used in conjunction with the loom supplied. No other additional ECU or engine management system can be used in conjunction with the standard ECU as supplied by Ginetta Cars Ltd. The ECU may be exchanged or electronically interrogated at any time, on the request of the Eligibility Scrutineer. The ECU diagnostic connector must be positioned in an accessible position, allowing the scrutineer free access to it at all times. The ECU must not be electronically accessed or interrogated by anyone other than the Eligibility Scrutineer or Ginetta Cars Ltd. technical staff under the direct supervision of the Eligibility Scrutineer.

**10.10.8** A standard 2009 engine map will be installed on to the ECU. This map must not be modified or changed in any way. If there are any discrepancies, the ECU may be removed and inspected by the Eligibility Scrutineer or Ginetta Cars Ltd.

**10.10.9** A standard 12 volt (nominal) alternator as supplied by Ginetta Cars Ltd. must be fitted. The minimum output of the alternator shall be 240 Watts, and the installation shall ensure that this output is available at all times.

**10.10.10** The starter motor must be of the type as supplied with the 2009 specification engine by Ginetta Cars Ltd.

**10.10.11** The wiring loom on the car must retain its original form and should not be altered in any way unless written consent has been given by Ginetta Cars Ltd. No additional wiring or components should be connected to any part of the wiring loom unless written consent has been given by Ginetta Cars Ltd.

## 10.11 COOLING SYSTEM

**10.11.1** The standard layout of the cooling system must be as supplied and must be in the location as set out by Ginetta Cars Ltd. The radiator must be of the type as supplied by Ginetta Cars Ltd. (Ginetta Part number GCG 0025) as supplied by Ginetta Cars Ltd and must remain in its location in front of the front most chassis member. The thermostat and housing may be replaced by a single flange and pipe, although if the thermostat is retained, it must be located in its original housing.

**10.11.2** Unless advised and approved by Ginetta Cars Ltd, it is not permitted to channel air from the nose of the bonnet.

**10.11.3** Additional ventilation holes may be cut into the sides of the bonnet to the official Ginetta template (as per Appendix C). Metal mesh grills, as supplied by Ginetta Cars Ltd. and unmodified, must be fitted to the ventilation apertures on the upper face of the bonnet. No extra panelling, either under floor or around the wheel arch area, is permitted.

**10.11.4** A template, verified via Ginetta Cars Ltd., may be used at scrutineering to ensure that the original bodywork shape and profile has not been altered in any such way that it deviates from its original shape and specification.

**10.11.5** It is permitted to fit a mesh grill to the aperture at the front of the bonnet. The mesh grill must be supplied by Ginetta Cars Ltd. and must remain to the same density. No alternative mesh grill, other than the component supplied by Ginetta Cars Ltd. may be used. It is not permitted to tape-up or cover the mesh in any way.

**10.11.6** The size of the bonnet apertures must remain unmodified and may not be covered or taped up in any way.

**10.11.7** No other modifications than those referred to above are permissible.

## 10.12 BRAKES

**10.12.1** The standard braking system as supplied by Ginetta Cars Ltd., consisting of 282 x 24mm max vented plain discs at the front, and 250 x 10.5mm plain discs at the rear, must be retained apart from the following permitted modifications.

**10.12.2** Brake master cylinders must be of the type as supplied by Ginetta Cars Ltd. with 0.7" bore size for the front brake line and 0.75" bore size for the rear brake line.

**10.12.3** The use of the following brake pads is mandatory:

Front: Mintex MGB642 M1155

Rear: Mintex MDB1287 M1155

Brake pads must be supplied by Ginetta Cars Ltd or their authorised dealer. In the event of an eligibility dispute, reference will be made to Mintex who will decide if the component is authentic.

**10.12.4** Steel brake lines may be substituted with braided equivalent.

**10.12.5** Brake bias may be altered using the standard balance bar supplied by Ginetta Cars Ltd. It is permitted to fit a hydraulic bias valve.

**10.12.6** Unless advised and approved by Ginetta Cars Ltd. additional ducting for the cooling of brakes is not permitted.

## 10.13 SUSPENSION

**10.13.1** The standard suspension components and configuration as supplied by Ginetta Cars Ltd. must remain unaltered except as specified below. Ginetta or the Eligibility scrutineer may choose to send any components back to the original manufacturers at any point to confirm their originality.

**10.13.2** The anti-roll bar must be as supplied by Ginetta Cars Ltd (Ginetta part number GCC 0035). No modification to the anti-roll bar is permissible and the part must retain its original dimensions of 19mm diameter and 1.12m length, measured along the centreline of the bar. The anti-roll bar chassis mounts must be as supplied by Ginetta Cars Ltd (Ginetta part number GCC 0019).

**10.13.3** The minimum ride height as measured in a vertical plane from a point on the chassis outrigger directly below the front pedal box bulkhead (see Diagram below), to a level ground surface below, must be minimum of 100mm. At the rear of the car a ride height minimum of 100mm must also be respected, as measured from the point of attachment

of the cross member immediately behind the driver's seat, at 90 degrees to the side chassis rail, in a vertical plane to the ground below. These measurements shall be applied with the driver normally seated on board, and with tyres normally inflated. If the ride height is measured at the end of an on-track session, the tyre pressures may not be altered prior to the ride height being checked.

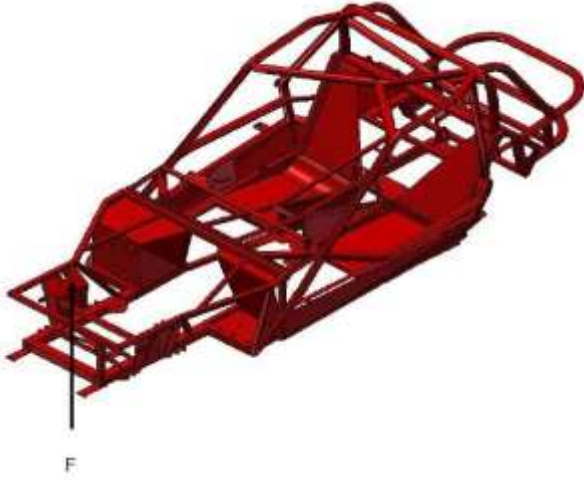

Diagram of chassis showing the position at which ride height measurements will be taken, front (F) and rear (R).

The front and rear locations for checking the ride height will be marked by the scrutineers at the first round of the championship or at the dedicated pre-season media day. These markings are for initial identification only and do not have to be carried for the full season. It is the responsibility of the driver / entrant to know where the ride height is checked.

**10.13.4** The front wheel camber angle may be adjusted by means of the top spherical joint within standard limits and with no modification.

**10.13.5** The front wheel toe in may be adjusted within standard limits and with no modification.

**10.13.6** Springs. Front and rear road springs are free provided that they are steel, and single rate. The use of additional 'helper' springs is not permissible.

**10.13.7** Bump rubbers may be cut down to a minimum of 20mm.

**10.13.8** Shock absorbers (AWD1313, Rear Shocks AWD1316) and supplied by Ginetta Cars Ltd must remain to the original manufacturers specification with no modifications.

**10.13.9** The standard track and wheelbase dimensions must be retained.

## 10.14 WHEELS

**10.14.1** The standard wheels (K & N Vectar Alloys 7J x 15" ET30) supplied by Ginetta Cars Ltd. may not be modified or substituted for others.

**10.14.2** The use of wheel spacers or other wheel spacing mechanism, is not permissible.

## 10.15 TYRES

**10.15.1** The only permitted tyres for use in this Championship are MICHELIN 195/50 R 15 V Pilot Exalto. These tyres must be supplied by Ginetta Cars or their designated tyre supplier. The tyres will be marked accordingly to certify that they have been supplied by Ginetta or designated tyre supplier. These tyres are treaded, road legal, and must remain road legal with a minimum tread depth of 1.6mm at all times, both during competition and during presentation for post-event scrutiny.

**10.15.2** The maximum number of tyres available to each car for use during each championship round (or 'meeting', where two rounds are timetabled over a single weekend) will be limited to 4 new tyres and 2 used tyres.

**10.15.3** Only when a 'wet race' has been declared by the Clerk of the Course, will the use of 'wet specification tyres' be permitted. The only permitted wet tyres for use in this Championship are MICHELIN 195/50 R 15 V Pilot Exalto. These tyres do not have to be included as part of the 6 tyres that are presented at scrutineering. These tyres must be supplied by Ginetta or their designated tyre supplier.

**10.15.4** The use of tyre heating equipment / heat retention devices, tyre treatments or compounds, is prohibited.

## 10.16 WEIGHT

**10.16.1** The minimum vehicle weight including driver is 745kg. The weight is intended to include the driver suitably dressed for competition, with safety helmet. It is emphasised that minimum weights must be respected at all times during both Qualifying and Competition. Failure to meet weight will be considered an offence under these regulations.

**10.16.2** In order to meet the criteria of 10.16.1 only, it is permitted to add ballast to the car. Such ballast must be formed of solid unitary blocks. They must be fixed by means of bolts only to the floor of the passenger seat well of the car and these fixings must be able to withstand acceleration / deceleration forces of 25G.

**10.16.3** Provision must be made for Scrutineers to affix seals to any ballast fitted.

**10.16.4** Following competition, the driver must remain available with the car under Parc Fermé conditions until released by Scrutineers, in order to ensure weighing is completed with the minimum of delay.

## **10.17 FUEL INJECTION AND FUEL TANK**

**10.17.1** The standard specification fuel cell as supplied by Ginetta Cars Ltd must be retained in its original position. The fuel delivery system must remain as original specification. It is permitted to insert a fuel filter between the fuel tank and the fuel pump.

**10.17.2** Unleaded pump fuel complying with the definition laid down in MI Yearbook Appendix 2 Article 28.2. No additives allowed.

**10.17.3** The standard fuel injector rail as supplied with the 2009 specification engine by Ginetta Cars Ltd must be retained. No other earlier or alternative version of the fuel injector rail shall be used.

**10.17.4** Only standard specification spray injectors, as supplied with the 2009 specification fuel injector rail kit by Ginetta Cars Ltd can be used.

**10.17.5** The fuel pressure in the engine fuel injector rail must remain in conformity with the Ford Motor Company workshop manual for 90PS version of the engine at all times.

**10.17.6** The fuel pressure relief valve must be connected and operational at all times.

**10.17.7** At the end of qualifying / races at least 3 litres of fuel from the tank of the competing car must be available to the eligibility scrutineer for analysis, if required. Compliance with minimum weight for the car will be taken before fuel is removed as part of any eligibility check.

## **10.18 SILENCING**

**10.18.1** The 2009 specification exhaust system as supplied by Ginetta Cars Ltd must remain as standard and may not be altered.

**10.18.2** A catalytic convertor, as supplied by Ginetta Cars Ltd (Ginetta part number GCO 0010), must be fitted as part of the exhaust system. The catalytic convertor must not be altered in any way and must retain its original form. A ventilation hole may be cut adjacent to the catalytic convertor to allow extra cooling.

**10.18.3** The silencer must be a 2009 specification part as supplied by Ginetta Cars Ltd (Ginetta part

number GCO 0012). The exhaust tail pipe must be a 2009 specification part as supplied by Ginetta Cars Ltd.

## **10.19 PRESENTATION**

Having due regard to the best interests of the Championship Sponsors, the Championship image and safety, competing cars are to be presented in a mechanically and visually acceptable condition. Organisers reserve the right to insist that such standards of presentation are maintained, as a condition of racing within the **2012** Ginetta Junior Ireland Championship.

## **10.20 NUMBERS AND DECALS**

**10.20.1** All cars must carry championship and trade sponsor decals. Competitors will be advised of these and their location on the car by the Ginetta Junior Ireland organisers. Ample free space will be available for individual sponsors requirements.

**10.20.2** Competitors will be supplied with three number squares incorporating the major sponsors logos. One must be affixed to each side of the car, in the position normally occupied by the doors. The third number must be located to the front / top aspect of the car so as to be clearly visible. Competition numbers must be affixed to these squares and to the front / top aspect of the car so as to be clearly visible.

**10.20.3** Failure to comply with regulations 10.20.1 or 10.20.2 will render the competitor ineligible for championship points in that round.

## **10.21 CONTACTS**

Michelin Tyres  
Tom Halliday  
Furbo  
Co Galway  
[docsport@haomail.com](mailto:docsport@haomail.com)

Mobile: 087 2638951

Class Representative: David McAulay  
[david@ginettajuniorireland.com](mailto:david@ginettajuniorireland.com)

Press / Media Officer: Paul Grogan  
[paulgrogan@ginettajuniorireland.com](mailto:paulgrogan@ginettajuniorireland.com)

Eligibility Scrutineer: as appointed by Motorsport Ireland Technical Advisory Group.