

APPENDIX 47 - FORMULA SHEANE TECHNICAL REGULATIONS

Issued: 14th April 2015

1. Description

The Formula Sheane Championship will comprise solely of cars produced by Sheane Cars Ltd. The cars will be single seated type with a spaceframe chassis powered by an 1800 cc over 'K' Series engine coupled to a five speed Audi gearbox.

These regulations are set out by Sheane Cars Ltd. and may be amended by same. Any amendment will be communicated 30 days in advance of becoming effective.

An eligibility scrutineer will be appointed and he/she will be the Final Judge of Fact.

Note: The term 'supplied by Sheane Cars Ltd.' means that the part/s can only be supplied by Sheane Cars Ltd. and are unmodified in any way. The term 'as supplied by Sheane Cars Ltd.' means that the part/s can be sourced elsewhere but must meet the same general specification as the original supplied by Sheane Cars Ltd.

The eligibility scrutineer will have a sample of each wishbone, front and rear rollbars, wing end plates, front and rear hubs and ecu for comparison purposes.

In the event of protest by another competitor, the driver must submit his car for rolling road check, which if found to be over the horse power limit the engine will be stripped for examination by the eligibility scrutineer. If found to be illegal the standard penalties will apply. The eligibility scrutineer, may, at his own discretion, request that a car be submitted for rolling road check at any time.

A Race meeting is defined as starting 1 week prior to the date of the race in question.

2. Chassis

The chassis will be a steel spaceframe manufactured supplied by Sheane Cars Ltd. incorporating a roll over hoop.

Non performance enhancing minor repairs and adjustments etc. may be made by an individual, however, should the work be contested by another individual, the final judge of fact will be consulted.

No major repairs or changes including altering moving points are permitted.

The chassis alterations depicted in Figs Chas 1 and Chas 2 are allowed. The alterations are discretionary.

3. Bodywork

Bodywork is supplied exclusively by Sheane Cars Ltd. The bodywork comprises of the nosecone, top cover, engine cover and sidepod covers, all constructed of fibreglass. It is each competitor's responsibility to maintain the body work in a safe and presentable manner and may be required

to replace items if found not to meet these criteria by the final judge of fact. No changes may be made to bodywork with the exception of holes etc. to accommodate mounting fasteners.

The floor comprises of the steel section contained in the main chassis and two panels either side. These panels must be as supplied by Sheane Cars Ltd. No extra aerodynamic devices are allowed including extended floors/undertrays.

Max Height at front of cockpit 740mm.

Max height of side pod in line with front of cockpit 450mm.

Max height of bodywork over rollbar 1050mm.

4. Tyres

The only tyre permitted for the class is as follows:

Front - AVON ACB 10 7.0/210-13 78V

Rear - AVON ACB 10 8.0/220-13 89V

5. Wheels

The only wheel types permitted for the class is supplied by Sheane Cars Ltd. and manufactured by Comptomotive Ltd. to Sheane Cars Ltd. specifications.

6. Wings

Two wings are fitted to the car one single at the front and a double wing on the rear. These can only be supplied by Sheane Cars Ltd. All wing sections and endplates must be unchanged from original dimensions.

Rear Wing

Overall width 920mm.

Depth of plane 220mm.

Distance between planes 215mm.

Bottom plane must be horizontal.

End plate 280 x 330mm.

An alternative rear wing plate (as per Fig ep1) supplied by Sheane Cars Ltd is permitted. This plate is an aesthetic change.

Distance from rear suspension cross member to rear of bottom plane 555mm or 705mm

It is permitted to strengthen the rear wing mounting using either of the rear wing mounting brackets supplied by Sheane Cars Ltd.

All 'Section 6. Wings' measurements max tolerance of plus/minus 10mm excepting accident damage. Top plane max angle 25mm from horizontal in slot, tolerance plus/minus 5mm.

Front Wing Plane

Horizontal: Height max 145mm.

Depth 160mm.

Overall width 1030mm.

Endplate length 255mm.

Depth 110 x 90mm.

Distance from chassis front to rear of wing plane 360mm.

7. Brakes

Disc brakes are fitted front and rear and are operated by two independent fluid systems. Callipers and discs are as supplied by Sheane Cars Ltd. unchanged in any way. Brake pad type is free. Brake fluid type is free. Brake lines must be of either steel or kunifer tubing or flexible braided hosing. Brake bias control is as fitted originally.

8. Front Suspension

Front suspension is dual inboard shock absorber configuration and comprises of the following components:

- a) Hub Assembly
- b) Wishbones
- c) Pushrods
- d) Bell crank
- e) Shock Absorber (bump stops may be fitted or removed)
- f) Springs
- g) Rod ends
- h) Anti roll bar

All above supplied by Sheane Cars Ltd. and must be assembled in the same configuration as Sheane Cars Ltd.

Front roll bar diameter 12mm.

Front roll bar maximum length including sliders 165mm.

Spring poundage free but must be 1.9DIA and 6" uncompressed length.

Front track width max 1470mm.

Rear roll bar diameter 16mm.

Rear roll bar length 220mm

Spring poundage free but must be 2.25DIA x 9" uncompressed length.

Rear track width max 1425mm.

9. Rear Suspension

Rear suspension is dual outboard shock absorber configuration and comprises of the following components:

- a) Hub Assembly
- b) Wishbones

- c) Trailing arms
- d) Tie Rod
- e) Shock Absorber (bump stops may be fitted or removed)
- f) Springs
- g) Rod ends
- h) Anti roll bar

All above supplied by Sheane Cars Ltd. and must be assembled in the same configuration as Sheane Cars Ltd.

10. Steering

Steering is rack and pinion type. Steering rack and track rods are supplied by Sheane Cars Ltd. spacers are permitted on tie rod ends to eliminate bump steer and must be assembled in the same configuration as Sheane Cars Ltd.

11. Safety

The car must be fitted with seat belts and a fire extinguisher that meet the current scrutiny requirements as per the current Motorsport Ireland yearbook. An operational red light must also be fitted to the rear of the car. ***An LED rain light is recommended.***

12. Fuel Delivery System

Tank and pump (***Part No. Bosch 058025964 or equivalent***) are supplied by Sheane Cars Ltd. A firewall consisting of an aluminium sheet must be fitted between the fuel tank and the drivers seat. ***The fuel pressure regulator is free but must not exceed a maximum of 3 Bar (Part No MKW10016).***

13. Fuel Type

Only unleaded RON95 type fuel may be used. All fuel must be of a type available on the major retail forecourts on sale to the public. No additives of any type including upper cylinder lubricants are allowed.

14. Fuel Injection System

Standard 1800 cc K Series system supplied by Sheane Cars Ltd.

Standard Rover injector no. 0280 155 884 Standard plastic inlet manifold with alloy or plastic throttle body DIA 48mm. Standard 3 bar pressure valve.

15. Air Filter

RU 3120. Supplied by Sheane Cars Ltd.

16. Engine

1800 cc K Series engine sealed and supplied by Sheane Cars Ltd.

Rover 1.8 K16 series (non VVC) Production Engine using standard lubrication, injection and ignition systems, sealed and supplied by Sheane Cars Ltd. **The engine must be supplied by one of the following approved engine providers: Sheane Cars Ltd., Keith Hogg, Enda O'Connor or Robbie Parks.**

Engine Block

Standard 18K 4F Unit fitted with standard wet liners and piston or Omega forged pistons supplied by David Sheane.

Bore 80m.

Stroke 89.5m.

Standard crankshaft and connecting rods (unbalanced)

1.8 conrod length 133.1mm.

1.6 conrod length 139.9mm

Cylinder Head

Unmodified, apart from machining necessary in reconditioning same. Ports as cast inlet max DIA ~~32.50~~ **34.50**

Standard inlet valves DIA 28mm seat angle 45°.

Standard exhaust valves DIA 24mm seat angle 45°.

Heads with triple angle seat are permitted with:

- Angles 15°
- Angles 45°
- Angles 60°

Minimum seat face width is: 1.25mm inlet. 1.40mm exhaust.

Max valve spring length uncompressed is 51.5mm.

Kent steel spring retainers, part no ST69 may be used.

Camshaft

Kent RK 1811 cams supplied by Sheane Cars Ltd. driven by C67 Vernier Pullies.

Lift 425" Duration 258.

Timing inlet 110° ATDC ~~Tolerance Plus/Minus 2°~~

Exhaust 105° BTDC ~~Tolerance Plus Minus 2°~~.

Seals

Every time a seal is broken on an engine the car must be returned to the rolling road for ~~assessment and adjustment~~ testing. Record of settings to be kept by David Sheane ~~which should include engine seal numbers and settings~~. Rolling Road test sheets should record the engine seal numbers and settings **such other data as may be required at the discretion of the eligibility scrutineer.**

17. Gearbox Adaptor

Gearbox adaptor and flywheel supplied by Sheane Cars Ltd.

18. Gearbox

Audi 3M unit sealed and supplied by Sheane Cars Ltd. The following gear ratios must be used and gears must be original parts.

1st Gear 3.45:1
2nd Gear 1.94:1
3rd Gear 1.28:1
4th Gear 0.90:1
5th Gear 0.73:1
Final Drive 4.11:1

The following ratios can be used in checking gear ratios. This ratio is the number of engine revolutions to driven wheel rotations.

1st Gear 14.18:1
2nd Gear 7.97:1
3rd Gear 5.26:1
4th Gear 3.70:1
5th Gear 3.00:1

Driveshafts and CV joints are as supplied by Sheane Cars Ltd.

19. Clutch

As supplied by Sheane Cars Ltd.

20. Cooling System

Two radiators **to be** used as supplied by Sheane Cars Ltd.

21. Lubrication System

Standard 'Rover Wet Sump'.

22. Exhaust

Complete exhaust system manufactured and supplied by Sheane Cars Ltd.

23. Ignition System, Engine Management Unit & Electrical System

The electrical system shall be as supplied by Sheane Cars Ltd. including operational starter and alternator. Battery is free.

A master reflash map, provided by Logic Automotive will be held by the eligibility scrutineer. This is the only ECU map approved for use by the class.

ECU's will be sealed by Sheane Cars Ltd. ~~and may be exchanged at random at eligibility scrutineers discretion.~~

The eligibility scrutineer is to be provided with 1 reflashed ECU to facilitate random checking of a competitors ECU.

24. Electronic Aids

All electronic driver aids such as launch control, abs, traction control, powershift units etc. are not permitted. An on board lap timing system and data logging is allowed.

25. Advertising Signage and Race Numbers

All competitors may be required to carry class sponsors logos etc. unless they directly clash with a personal sponsor and have received prior permission by the judge of fact. Competitors will also be required to place race numbers etc. in designated locations. All race numbers will be assigned by the Formula Sheane Association in accordance with the Championship positions from the previous year.

26. Ride Height

The minimum ride height from the lowest part of the car excluding the wheels is 40mm.

27. Weight

The minimum weight for the car in race trim, i.e. including all fluids at normal levels, except fuel is 460kgs. The minimum weight for the car as above including driver is 550kgs. NB. Race trim weight includes nose and front wing. ***Nose and front wing nominal weight is 5KG.***

28. Engines Output

Maximum BHP at wheels to be 145BHP as measured by Track-Day Performance. Engines sealed by David Sheane during rolling road test. If a greater variation in engine power is discovered during rolling road test it will be subject to further investigation. The championship winning car will be returned to rolling road test at the racing seasons end. ~~If a seal is broken on an engine a rolling road test must be completed no later than the second race meeting, in which the engine has been used, after the seal breakage is noted.~~ Modified 1/5/13

To facilitate a competitor who experiences mechanical difficulties (e.g. a blown head gasket) during a race meeting: that competitor will be permitted to complete that race meeting (see definition of race meeting) provided that the repaired engine is resealed after repair and the seal numbers are recorded by the eligibility scrutineer AND the engine is rolling roaded prior to competing again.

It is the competitor's responsibility to demonstrate vehicle compliance with the regulations, rolling road printouts must be available for inspection. Said responsibility is the competitors alone, not David Sheane's, the Scrutineers or another's. To facilitate accurate record keeping and in compliance with accepted motorsport protocols, any competitor who wishes to break any seal for any reason, must inform the eligibility scrutineer prior to breaking that seal. Where a competitor is found to have broken a seal without informing the eligibility scrutineer,

that competitor will be subject to a 5 place grid penalty at the first available opportunity. In the event of the eligibility scrutineer being uncontactable, the competitor shall notify the nominated Eligibility Liaison Official.

All rolling road test costs will be covered by drivers.

All cars must be tested and sealed in order to qualify for points.

CLASS SCRUTINEER: MI Panel.

Fig: CHAS 1

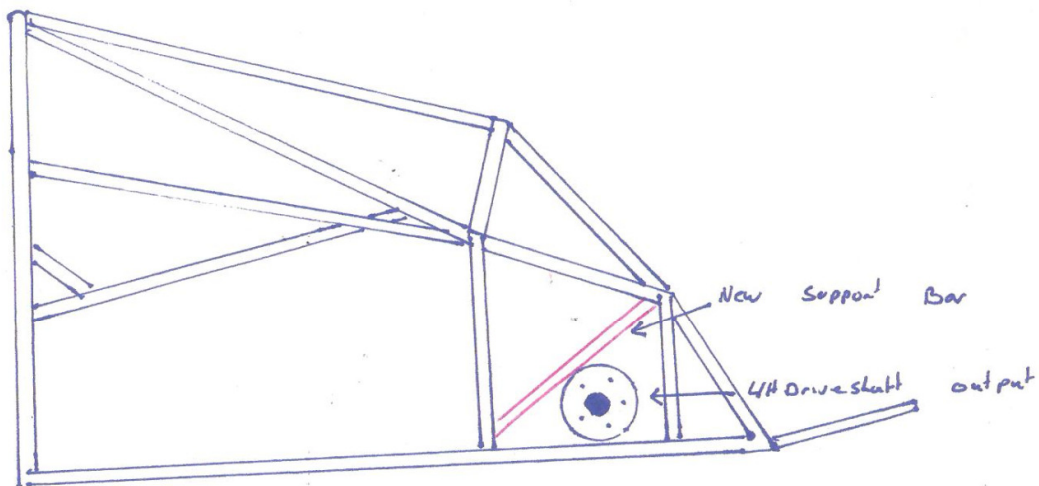

L/H view of Rear of chassis

Fig CHAS 2

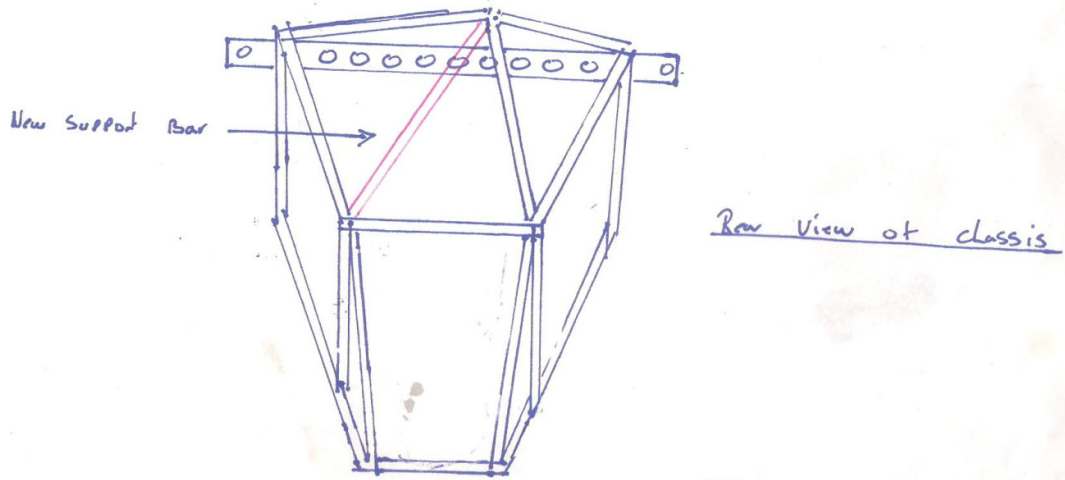

Fig EP1

